



classics



adico: classics

ADICO nasce em 1920 e transforma-se numa das maiores empresas de mobiliário metálico da Europa, sendo neste momento uma das empresas mais antigas do setor em atividade. Visitar o Passado e Construir o Futuro... Foi o mote para relançar esta coleção, revitalizando as décadas de 20/30 da empresa.

Entramos na sala das recordações, retiramos um pouco do pó e descobrimos um conjunto de fantásticas expressões de arte, sim arte! De construir produtos com uma apurada linguagem, onde tudo faz sentido: forma, componentes, raios, ângulos, talvez puro desenho nos seus anos de ouro.

Sentimos as diversas influências, entre as quais a escola alemã (Bauhaus), a escola francesa com uma brisa nórdica, deixando marcas através dos tempos sob a forma de um conjunto de produtos que contam quase um século de história.

Reconstruir com cuidado, foi o que nos moveu, mas não queríamos estragar porque era difícil melhorar, então, com o desenho de outrora e a técnica de agora, demos vida a esta coleção, para si que é especial...



Born in 1920, ADICO became one of the largest metal furniture companies in Europe and is today one of the oldest companies in this industry. Visit the Past and Build the Future... was the motto for relaunching this 20's/30's revival collection.

We entered the memory room, removed some dust and discovered a set of fantastic art expressions (yes art!), products build with such a precise language where everything makes sense: form, components, radius, angles, perhaps pure design in their golden age.

We can feel different influences such as German school (Bauhaus), French school with a Nordic breeze leaving traces in a set of products throughout the years counting almost a century of history.

To rebuild carefully was what moved us, without spoiling though, as it was difficult to improve. So, an erstwhile drawing and modern technique brought this collection to life, especially for you.

uk

ADICO est né en 1920 et devient un des plus grands fabricants de meubles métalliques de l'Europe, en étant aujourd'hui une des plus anciennes entreprises du secteur en activité. Visiter le Passé et Construire l'Avenir... était la devise pour relancer cette collection en revitalisant les années 20/30 de l'entreprise.

Nous rentrons dans la salle des souvenirs, enlevons un peu de la poussière et découvrons un ensemble d'expressions fantastiques d'art, oui d'art! de construire des produits avec un langage apuré, où tout fait du sens: forme, composantes, rayons, angles, peut-être pur dessin dans leurs années d'or.

Nous sentons des influences diverses, y comprises l'école allemande (Bauhaus), l'école française avec une brise nordique, laissant des traces à travers les âges sous la forme d'un ensemble de produits qui compte près d'un siècle d'histoire.

Reconstruire avec du soin, c'est ce qui nous a motivé, mais nous ne voudrions pas gâcher parce qu'il était difficile d'améliorer, puis, avec le dessin d'autrefois et technique actuelle, nous avons donné vie à cette collection, pour vous spécialement.

fr

ADICO, gegründet in 1920, verwandelte sich in einer der größten Metallmöbel-Unternehmen in Europa und ist heute eine der ältesten Unternehmen dieser Branche. Die Vergangenheit Besuchen und dabei die Zukunft bauen... war das Motto für die Einführung und Wiederbelebung dieser 20er/30er Jahren Kollektion.

Wir betraten den Erinnerungsraum, entfernten etwas Staub und fanden einen Satz von fantastischen Ausdrucksformen von Kunst (ja Kunst!), mit einer präzisen Sprache bearbeitete Produkte, wo alles Sinn macht: Form, Komponente, Radius, Winkel, vielleicht reines Design in ihren goldenen Jahren.

Man fühlt die vielfältigen Einflüsse, darunter die deutsche Schule (Bauhaus), die französische Schule mit einer nordischen Brise, haben durch die Zeiten, Spuren in einer Reihe von Produkten hinterlassen, die fast ein Jahrhundert Geschichte enthalten.

Sorgfältig wiederaufbauen war das, was uns bewegte, aber wir wollten nicht verderben, weil es schwierig war zu verbessern. So brachten wir, mit Zeichnung von eins und heutige Technik, diese Kollektion zum Leben, besonders für Sie.

de

ADICO nace en 1920 y se transforma en una de las mayores Industrias de mobiliario metálico de Europa, siendo en este momento una de las empresas más antiguas del sector en la actividad. Visitar el Pasado y Construir el Futuro... fue la nota para lanzar esta colección revitalizando las décadas de los años 20 y 30 de la empresa. Entramos en la sala de los recuerdos, retiramos un poco de polvo y descubrimos un conjunto de fantasías y expresiones de arte, sin arte! De construir los productos con un depurado lenguaje, donde todo hace sentido: forma, componentes, radios, ángulos, tal vez el puro diseño de los años de oro. Sentimos las diversas influencias, entre las cuales la escuela alemana Bauhaus, la escuela francesa con una brisa nórdica, dejando marcas a través de los tiempos sobre la forma de un conjunto de productos que cuentan con un siglo de historia. Reconstruir con cuidado, fue lo que nos movió. No queríamos perder lo que era difícil de mejorar. Entonces, con el diseño antiguo y la técnica de ahora, damos vida a esta colección, para si que eres especial...

es

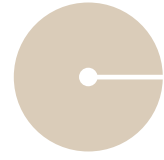

adico backup:



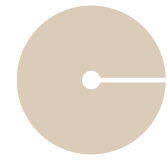

adico archive:



1920

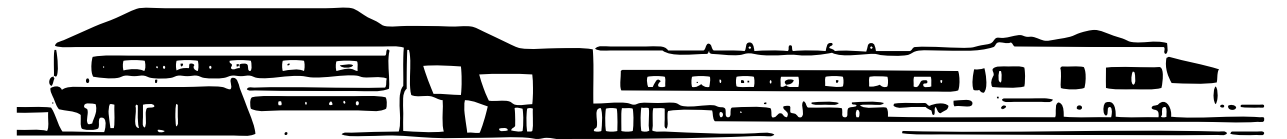
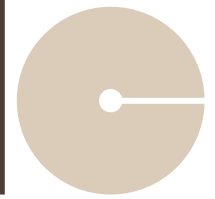

273



273-A



282



274-B



298





120



224-A



328



270-A



296



748



745





119-E



280

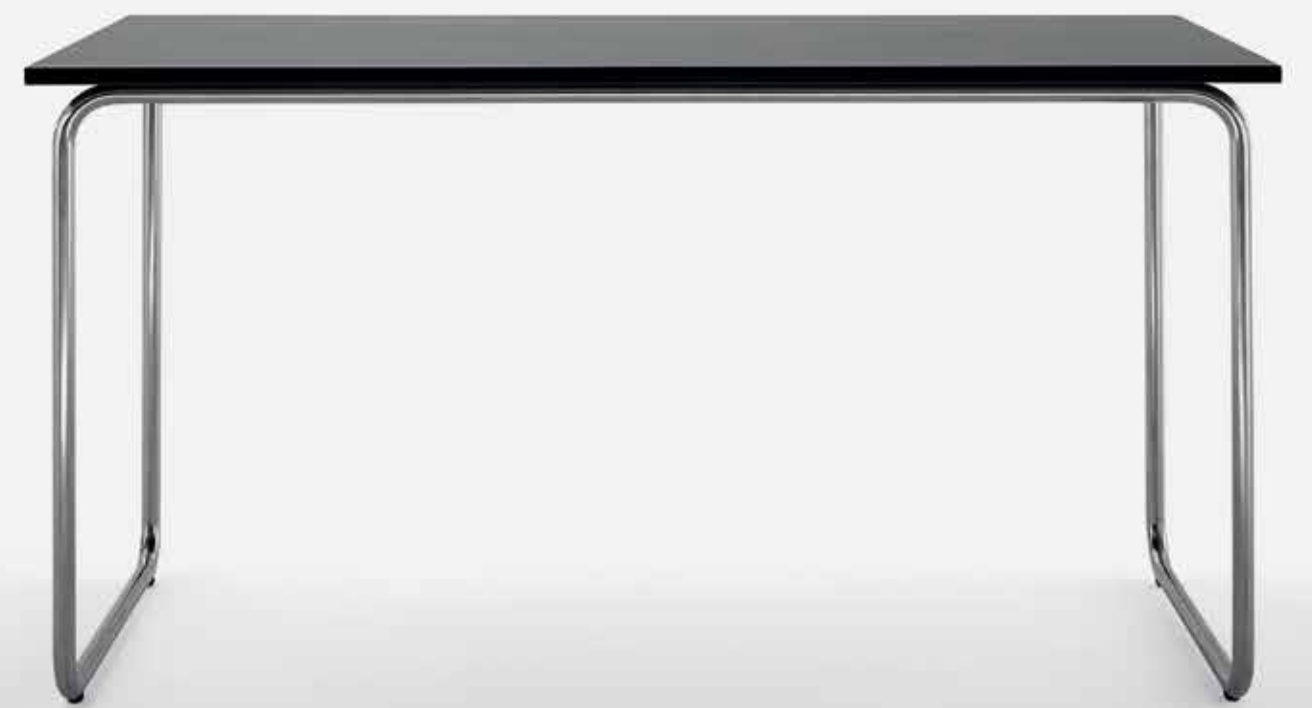

704



704-H



211/213



660



109



109-A

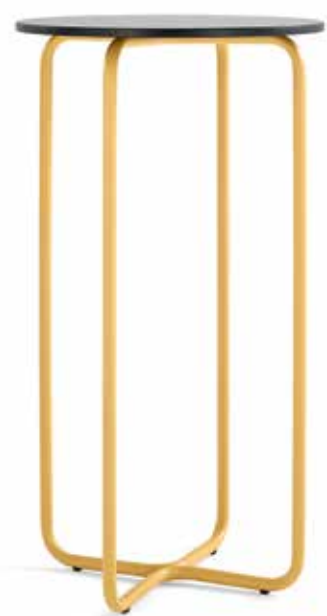

201-G



341



310



226



(NOT AVAILABLE FOR SALE IN THE GERMAN MARKET)

226-B



284



261-E





5014





adico classics:

info



adico classics:
info

a: estruturas. structures. structures. strukturen. estructuras

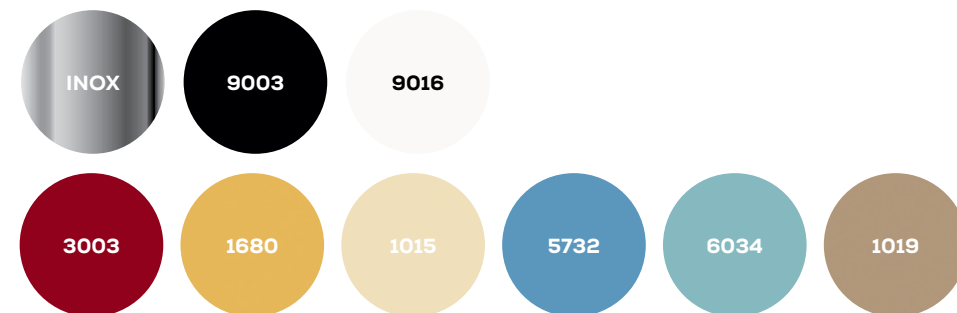

superfícies. surfaces. surfaces. oberflächen. superficies

b: madeiras. woods. bois. wald. mad-

c: mármore. marble. marbre. marmor. marmol

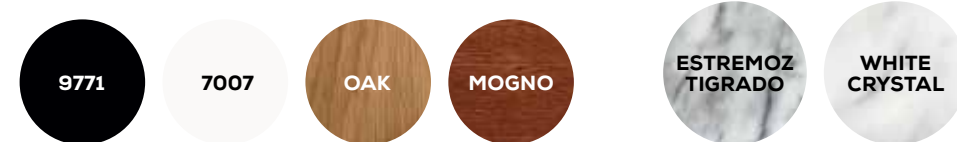

d: ecopele. eco bonded leather. eco cuir. öko leder. cuero ecológico



e: couros. leather. cuir. leder. cuero

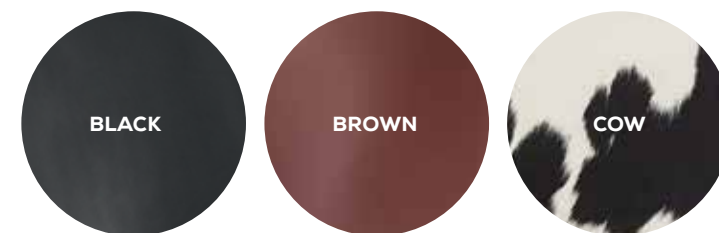

f: têxtil. fabrics. textile. stoff. textil

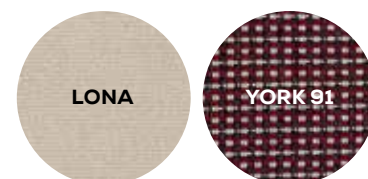

273
-
2025 x 850 x 400/600



273-A
-
2000 x 800 x 400



282 **O**
- -
600 x 600 x 750 mm ø600 x 750 mm



274-B **a/b/d**
- -
440 x 420 x 770 mm 440 x 420 x 800



298
-
710 x 895 x 400/790



/3 **/2** **a/d**
- - -
1900 x 895 x 400/790 mm 1300 x 895 x 400/790 mm



120 a/b
 -
 120-A: 600 × 600 × 350 mm
 120-B: 1000 × 1000 × 350 mm
 120-C: 1200 × 800 × 350 mm



328 a 270-A a/d
 - - -
 595 × 520 × 1720 mm 440 × 505 × 480/910



224-A a/d
 -
 540 × 550 × 480/790



748 o a/b/c
 - - -
 600 × 600 × 750 mm ø600 × 750 mm



296 a/b
 - -
 1200 × 735 × 750 mm* 1400 × 735 × 750 mm
 1200 × 835 × 750 mm 1400 × 835 × 750 mm

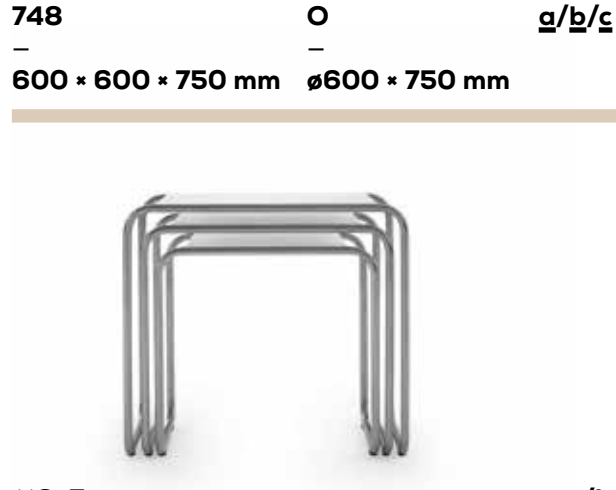

119-E a/b
 -
 119-E/A: 520 × 390 × 500 mm
 119-E/B: 590 × 390 × 550 mm
 119-E/C: 660 × 390 × 600 mm



745 /2
 - -
 600 × 720 × 430/840 mm 1130 × 720 × 430/840 mm



/3 a/d/f
 - - -
1650 × 720 × 430/840



704 a/b
 -
 445 × 475 × 450/845



280 a/b
 -
 1200 × 700 × 750 mm
 1400 × 800 × 750



704-L a/b
 -
 560 × 525 × 400/790



213 211 a
 - - -
 750 × 410 × 1575 mm 650 × 410 × 1575 mm



660
—
545 × 665 × 400/760 mm

a/f



226
—
400 × 520 × 460/830

a/b



226-B
—
545 × 520 × 460/830

a/b



201-G
—
385 × 410 × 560 mm

a/b



109
—
ø800 × 750 mm

109-A
—
ø600 × 1100 mm

a/b



284
—
400 × 500 × 460/830

a/b



261-E
—
ø550/ø700 × 350/580 mm

a/b



341
—
365 × 365 × 450 mm

a/b



310
—
610 × 430 × 280/540 mm

a/b



5014
—
760 × 810 × 330/900 mm

a/e



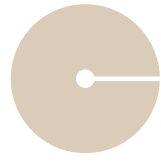

**adico classics:
archive**

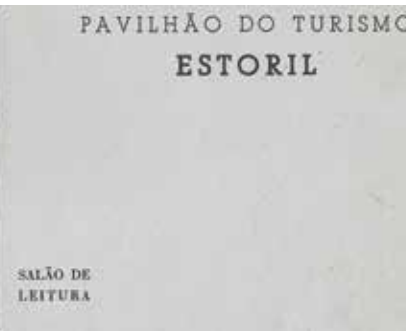
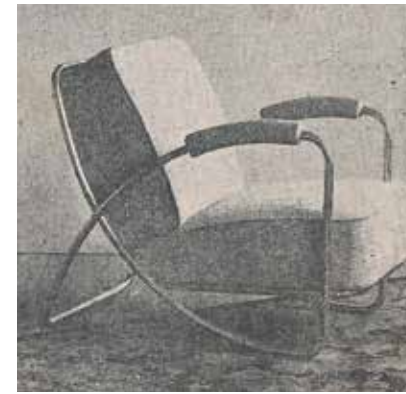
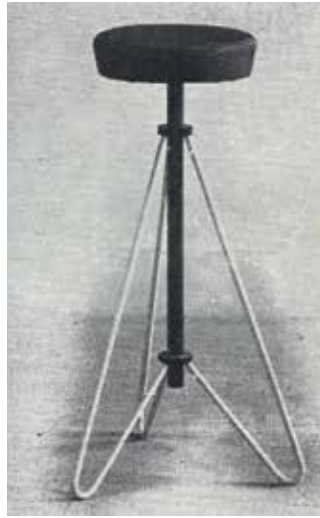



créditos. credits

Graphic Design/Art Direction: www.veer-design.com
Fotografia. Photography: www.viriato.com.pt
Impressão. Printing: www.orgal.pt
©Adico JULHO/2014

contactos.contacts

Adico Mobiliário Metálico, Lda.
Rua Comendador Adelino Dias Costa, 74
P.O. Box 2,
3864-758 Avanca
Portugal

T. +351 234 850 850
F. +351 234 850 851

www.adico.pt

Geral. General: adico@adico.pt
Comercial. Commercial: comercial@adico.pt
Investigação & Desenvolvimento. R&D: id.tecnico@adico.pt

*NOTA: AS CORES REPRESENTADAS SÃO MERAMENTE INDICATIVAS, PODENDO NÃO RESPONDER EXACTAMENTE À REALIDADE.
*NOTE: THE PRINTED COLOURS IN THIS CATALOG MAY DIFFER FROM THE REAL COLOUR.



www.adico.pt

